

LiFePO4 Battery System



USER MANUAL



ES Series II

In order to prevent improper operation before use, please carefully read this manual.

Contents

- 1 Introduction** 1
- 2 Symbols** 1
- 3.Safety** 2
- 4.Handling** 2
 - 4.1 Installation..... 2
- 5.Response to Emergency Situations** 2
 - 5.1 Warning Labels 3
- 6.Product Information** 3
 - 6.1 Battery Module Specifications 3
- 7.Electrical Connections** 4
 - 7.1 Battery System Features 4
 - 7.2 Electrical Interface Description of ES series..... 4
 - 7.3 Switch On/Off 5
 - 7.4 Description for Communication port 5
- 8.Installation**6
 - 8.1 Items in the package6
 - 8.2 Tools7
 - 8.3 Installation instructions 7
 - 8.4 Install Enviroment 8
 - 8.5 Terminal Connection 8
 - 8.6 LCD indication description.....9
 - 8.7 Communication instructions10
- 9.WARRANTY**12
- 10.TROUBLESHOOTING AND MAINTENANCE**12
 - 10.1 Maintenance.....12











1.INTRODUCTION

The document describes the installation, commissioning, maintenance and troubleshooting of the following low voltage battery listed below.

The battery chemistry of these products is Lithium Iron Phosphate. This manual is designed for qualified personnel only. The tasks described in this document should be performed by authorized and qualified technicians only.

After Installation the Installer must explain the user manual to the end user.

2.SYMBOLS

	Caution, risk of electric shock.
	Do not place nor install near flammable or explosive materials.
	Install the product out of reach of children.
	Read the instruction manual before starting installation and operation.
	Do not dispose of the product with household wastes.
	Recyclable.
	Disconnect the equipment before carrying out maintenance or repair.
	Observe precautions for handling electrostatic discharge sensitive devices.
	Protective Class 1.
	Caution, risk of electric shock, energy storage timed discharge.

3.SAFETY

Any work on the Batteries should be handled by authorized technicians and hence it is understood that the technicians should familiarize themselves with the contents of this manual before any maintenance or installation is carried out on the system.

4.Handling

- Do not expose battery to open flame.
- Do not place the product under direct sunlight.
- Do not place the product near flammable materials. It may lead to fire or explosion in case of accident.
- Store in a cool and dry place with ample ventilation.
- Store the product on a flat surface.
- Store the product out of reach of children and animals.
- Do not damage the unit by dropping, deforming, impacting, cutting or penetrating with a sharp object. It may cause leakage of electrolyte or fire.
- Do not touch any liquid spilled from the product. There is a risk of electric shock or damage to skin.
- Always handle the battery wearing the insulated gloves.
- Do not step on the product or place any foreign objects on it. This can result in damage.
- Do not charge or discharge damaged battery.

4.1 Installation

- After unpacking, please check the product for damages and missing parts.
- Make sure that the inverter and battery is completely turned off before commencing installation.
- Do not interchange the positive and negative terminals of the battery.
- Ensure that there is no short circuit of the terminals or with any external device.
- Do not exceed the battery voltage rating of the inverter.
- Do not connect the battery to any incompatible inverter.
- Do not connect different battery types together.
- Please ensure that all the batteries are grounded properly.
- Do not open the battery to repair or disassemble. Only Sunness is allowed to carry out any such repairs.
- In case of fire, use only dry powder fire extinguisher. Liquid extinguishers should not be used.
- Install the battery away from children or pets.
- Do not use battery in high static environment where the protection device might be damaged.
- Do not install with other batteries or cells.

5.RESPONSE TO EMERGENCY SITUATIONS

The batteries comprise of multiple batteries connected in series. It is designed to prevent hazards or failures. However, Sunness cannot guarantee their absolute safety. Under exposure to the internal materials of the battery the following recommendations should be carried out by the user.

- If there has been inhalation, please leave the contaminated area immediately and seek medical attention.
- If there has been contact with eyes, rinse the eyes with running water for 15 minutes and seek medical attention immediately.
- If there has been contact with the skin, wash the contacted area with soap thoroughly and seek medical attention immediately.
- If there has been ingestion, induce vomiting and seek medical attention.

Fire Situation

Use a FM-200 or Carbon Dioxide (CO2) fire extinguishers to extinguish the fire if there is a fire in the area where the battery pack is installed. Wear a gas mask and avoid inhaling toxic gases and harmful substances produced by the fire.

5.1Warning Labels

Warning labels and other relevant labels are attached on the battery pack.

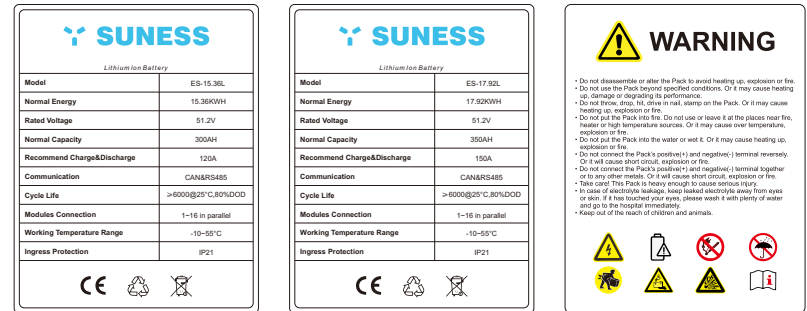

6.PRODUCT INFORMATION

ES series photovoltaic energy storage system is a 48V energy storage system based on lithium-ion ferrous phosphate battery. It is equipped with a customized battery management system(BMS), Which is designed for energy storage applications of household photovoltaic power generation users. In the daytime, the surplus power of photovoltaic generation can be stored in the battery. At night or when necessary, the stored energy can be provided to the electrical equipment, it can improve the use efficiency of photovoltaic power generation, peak-load shifting, and provide emergency standby power.

6.1 Battery Module Specifications

Models	ES-15.36L	ES-17.92L
Total Energy	15.36KWH	17.92KWH
Capacity	300Ah	350Ah
Nominal Voltage	51.2V	51.2V
Voltage Range	48-57.6V	48-57.6V
MAX. Charge & Discharge Current	120A	150A
Peak Charge & Discharge Current(for10sec.)	150A	200A
Scalable	1~16 in parallel	
Communication	CAN_RS485	
Enclosure Protection Rating	IP21	
Working Temperature Range	-10 ~ 50	
Cycle Life	> 6,000 Cycle@ 80% DOD / 25°C / 0.5C, 60%EOL	
Warranty	5 years	
Certification	IEC62619, UN38.3, CE	
Net Weight(KG)	93KG	117KG
Product Dimension(MM)	575 × 640 × 265MM	717 × 640 × 265MM

7. Electrical Connections

7.1 Battery System Features

The batteries have been fitted with multiple protection systems to ensure the safe operation of the system. Some of the protection system includes:

- Inverter interface protection: Over voltage, Over current, External Short Circuit, Reverse Polarity, Ground Fault, Over Temp, In rush current.
- Battery Protection: Internal Short Circuit, Over voltage, over current, over temp, Under voltage The battery system contains the following Interface to allow it to connect and operate efficiently.

7.2 Electrical Interface Description of ES series

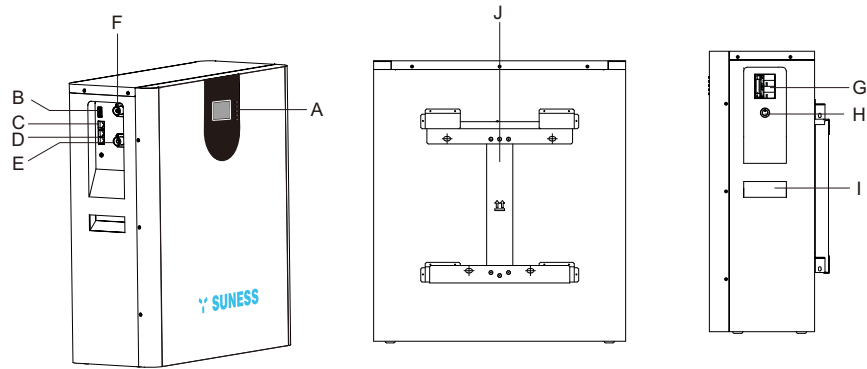

Code	Name
A	LCD Display
B	ADD
C	CAN Communication
D	RS485 Communication
E	BAT+
F	BAT-
G	Power Breaker
H	Power Switch
I	Handle
J	Wall mount

7.3 Switch On / Off

Switch on: close the breaker to the ON block, press and hold Power switch for 1 seconds, the battery will perform self-test before output. The LCD will show SOC.

Switch off: press and hold Power switch for 1 seconds, close the breaker to the OFF block, the battery will shut down directly.

7.4 Description for Communication port

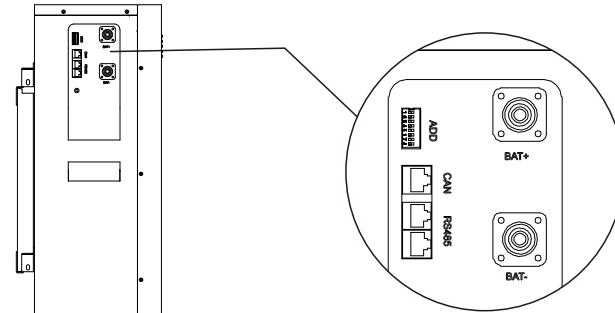

CAN

Pin	Function Definitions	Function Declaration
1	NC	
2	NC	
3	NC	
4	CANH	CANH
5	CANL	CANL
6	NC	
7	NC	
8	NC	

RS485

Pin	Function Definitions	Function Declaration
1	485-1B	RS485-1B
2	485-1A	RS485-1A
3	DI+	DI+
4	485-2A	RS485-2A
5	485-2B	RS485-2B
6	DI-	DI-
7	485-1A	RS485-1A
8	485-1B	RS485-1B

RS485

Pin	Function Definitions	Function Declaration
1	485-1B	RS485-1B
2	485-1A	RS485-1A
3	DO+	DO+
4	485-2A	RS485-2A
5	485-2B	RS485-2B
6	DO-	DO-
7	485-1A	RS485-1A
8	485-1B	RS485-1B

8. INSTALLATION

8.1 Items in the package

Please check if following items are including with the package:



Code	Items	Code	Items
1	Wall bracket	4	User manual
2	Communication line 1	5	Guarantee card
3	screw	6	cables

8.2 Tools



Screw Driver



Crimping Modular



Safety Shoes



Multimeter



Safety Gloves



Safety Goggles



Plier



Ribbon

8.3 Installation instructions

Installation Location Requirements

Consider the following points before selecting where to install:

- Do not mount the battery on flammable construction materials.
- The ambient temperature should be between 0°C and 45°C to ensure optimal operation.
- The recommended installation position is to be adhered to the wall vertically.
- Be sure to keep other objects and surfaces as shown in the right diagram to guarantee sufficient heat dissipation and to have enough space for removing wires.

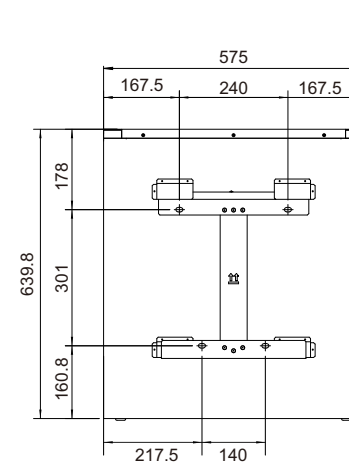

ES-15.36L

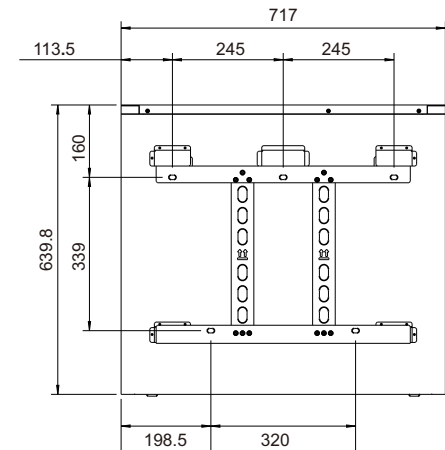

ES-17.92L

Installation Procedure

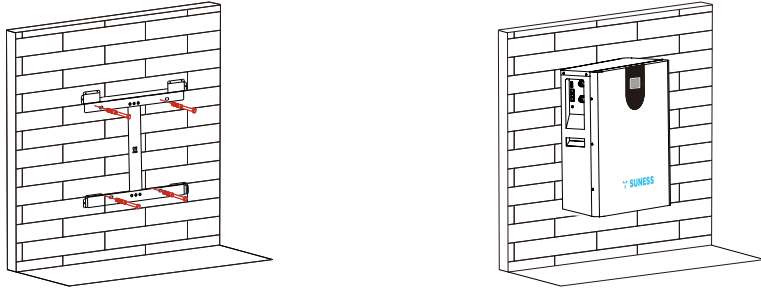

8.4 Install Environment

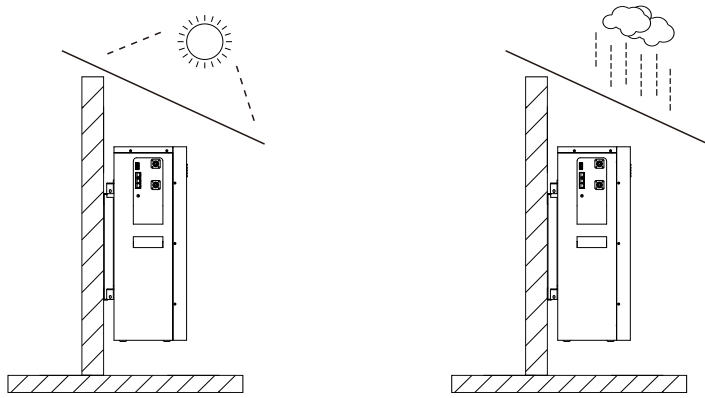

Note: Build sun & rain shade to avoid direct exposure to sunlight and rain.

8.5 Terminal Connection

Power terminal

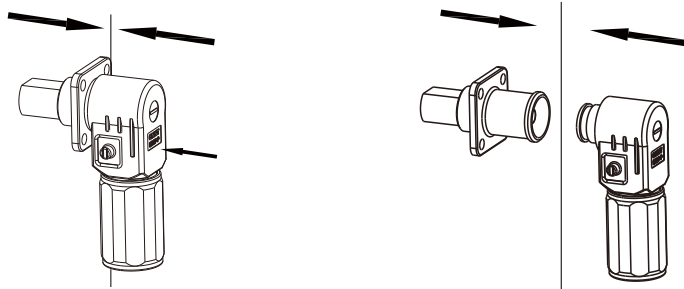

Note: Press the position indicated in the figure above before disconnecting the power terminal.

Communication terminal

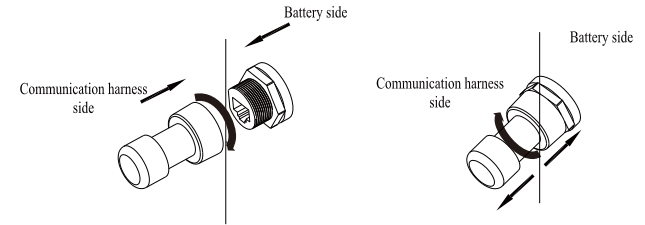

8.6 LCD Display icons

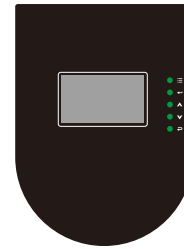

Description of key functions

- Menu: Menu key, normal is high, press to set low.
- Enter: Enter submenu, normal is high, press to set low.
- UP: Cursor up/page up, normal is high, press to set low.
- Down: Cursor down/page down, normal is high, press to set low.
- Esc: Cancellation.

LCD light-up method

BMS goes into hibernation: Press menu to light up the LCD.
The LCD goes to sleep within 1 minute without a key press: press any key to illuminate the LCD.

Version information

- BMS version information
 - BMS software versions: xxxxxxxx (BMS reads the last 8 bits of the software version)
 - BMS hardware version: xxxxxxxx (i.e. PCB version number)
- LCD version information
 - LCD software version: xxxxxxxx
 - LCD hardware version: xxxxxxxx

Battery parameter acquisition

- Total voltage: xxxxV
- Current: xxxxA (Charge is '+', discharge is '-')
- Temperature acquisition (Full screen page turn)
 - Cell temperature 01~04: xx°C
 - PCB temperature 02: xx°C (Communication failure is displayed as temperature 05:00 °C)
 - Ambient temperature: xx °C (Communication failure is displayed as temperature 06:00 °C)
- Cell voltage (Full screen page turn)
 - Voltage 01~16: xxxxmV
- SOC: xxxx%
- Nominal capacity: xxxxAh
- Remaining capacity: xxxxAh
- Number of cycles: xxxx

Battery working state (Full screen page turn)

- Status: Idle / Charging / Discharging
- Alarm Status (Full screen page turn)
 - Overvoltage alarm / Undervoltage alarm / Overtemperature alarm / Undertemperature alarm / Capacity alarm / Differential pressure alarm / Overcurrent alarm / Anti-connection alarm
- Protection Status (Full screen page turn)
 - Overvoltage protection / Undervoltage protection / Over-temperature protection / Undertemperature protection / Overcurrent protection / Short-circuit protection
- Failure alarm (Full screen page turn)
 - Sample line / Charging tube / Discharge tube: Normal / damaged
- Number of short circuit protection: xxxx
- Temperature protection times: xxxx
- Overcurrent protection times: xxxx
- Overcharge protection times: xxxx
- Overdischarge protection times: xxxx

8.7 Communication instructions

CAN Communication

The battery pack can communicate with the inverter via CAN, baud rate: 500K

RS485 Communication

The battery pack can communicate with the host computer via RS485 for data communication, baud rate: 19200

DIP switch

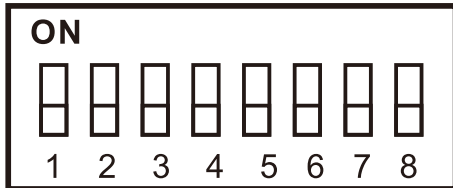

Dipswitches bit1 to bit8 are defined: bit1 to bit4 for setting the address, bit5 to bit8 for setting the number of slaves.

Slave settings: bit 1 to bit 4 are set according to the device order, slave address range 1 to 15. Bit 5 to bit 8 are fixed to 0. See slave settings table.

Host settings: bit1 to bit4 are 0, the host address is fixed to 0, bit5 to bit8 are set according to the number of slaves connected in parallel. See table for host settings.

Host settings

Number of in parallel	Dipswitch position				Instruction
	#5	#6	#7	#8	
2	ON	OFF	OFF	OFF	2 units in parallel
3	OFF	ON	OFF	OFF	3 units in parallel
4	ON	ON	OFF	OFF	4 units in parallel
5	OFF	OFF	ON	OFF	5 units in parallel
6	ON	OFF	ON	OFF	6 units in parallel
7	OFF	ON	ON	OFF	7 units in parallel
8	ON	ON	ON	OFF	8 units in parallel
9	OFF	OFF	OFF	ON	9 units in parallel
10	ON	OFF	OFF	ON	10 units in parallel
11	OFF	ON	OFF	ON	11 units in parallel
12	ON	ON	OFF	ON	12 units in parallel
13	OFF	OFF	ON	ON	13 units in parallel
14	ON	OFF	ON	ON	14 units in parallel
15	OFF	ON	ON	ON	15 units in parallel

Slave settings

Address	Dipswitch position				Instruction
	#1	#2	#3	#4	
1	ON	OFF	OFF	OFF	Address 1
2	OFF	ON	OFF	OFF	Address 2
3	ON	ON	OFF	OFF	Address 3
4	OFF	OFF	ON	OFF	Address 4
5	ON	OFF	ON	OFF	Address 5
6	OFF	ON	ON	OFF	Address 6
7	ON	ON	ON	OFF	Address 7
8	OFF	OFF	OFF	ON	Address 8
9	ON	OFF	OFF	ON	Address 9
10	OFF	ON	OFF	ON	Address 10
11	ON	ON	OFF	ON	Address 11
12	OFF	OFF	ON	ON	Address 12
13	ON	OFF	ON	ON	Address 13
14	OFF	ON	ON	ON	Address 14
15	ON	ON	ON	ON	Address 15

9. WARRANTY

The warranty shall not cover the defects caused by normal wear and tear, inadequate maintenance, handling, storage faulty repair, modifications to the battery or pack by a third party other than Suness, failure to observe the product specification provided herein or improper use or installation, including but not limited to the following.

- Damage during transport or storage.
- Incorrect Installation of battery into pack or maintenance.
- Use of battery pr pack in inappropriate environment.
- Improper, inadequate, or incorrect charge, discharge or production circuit other than stipulated herein.
- Incorrect use or inappropriate use.
- Insufficient ventilation.
- Ignoring applicable safety warnings and instructions.
- Altering or attempted repairs y unauthorized personnel.
- In case of force majeure (ex: lightning, storm, flood, fire, earthquake, etc.).
- There are no warranties-implicit or express-other than those stipulated herein. Suness shall not be liable for any consequential or indirect damages arising or in connection with the product specification, battery or pack.

10. TROUBLESHOOTING AND MAINTENANCE

10.1 Maintenance

- 1.Regularly check whether the service environment of the battery meets the requirements, and the installation position should be far away from the heat source.
- 2.In case of one of the following situations, it needs to be charged in time:
 - The battery is often under charged;
 - The battery has been out of use or stored for more than 3 months.
- 3.Regularly check whether the battery and its supporting terminals, connecting cables and indicator lights are normal.

- Problem determination based on the following points

- Whether the red light on the LCD is on
- Whether the battery can be output voltage or not.

- Preliminary determination steps

Battery system cannot work, when DC switch on and POWER on, the LCD doesn't light up, please consider contact the local distributor.